

Sightglass Wiper type SW I

DATA SHEET 02.01

- for circular sightglass assemblies to DIN 28120 or similar as well as screwed sightglass assemblies

Installation:

Into sightglass disc with 10,5 mm central hole (to DIN 7080/8902 or similar, see also data sheet 00.03); suits sightglass assemblies to DIN 28120 from nominal size DN 50 to DN 400 as well as screwed sightglass assemblies similar to DIN 11851, DN 50, 65, 80, 100, 125, 150.

Application:

For manual cleaning, when required, of inside glass surface in sightports.

Operating conditions:

Vacuum tight; pressure tight to at least 2 bar and, depending on glass diameter, to 6 bar. Max. permissible temperature 220° C (though this depends on glass type used).

Possible combinations:

Unit can simultaneously be combined with a spray device. Combination with Lumistar luminaire mounted on the sightglass unit is possible from viewing dia. 125 (DIN 28120, DN 100) depending on luminaire size (see table overleaf). Lumiglas luminaire series USL and ESL can also be combined with the unit.

With screwed sightglass assemblies combination with Lumiglas luminaire model SLM or Lumistar ME is possible with size DN 125.

Certification/Testing:

Certification issued by the state material testing authority of Nordrhein-Westfalen, Dortmund, are available.

Assembly breakdown and material alternatives

for complete supply:

Item	1	T grip (or ratchet-drive lever at extra cost)
		- Polycarbonate (bush brass) ¹⁾
	2	locating pins - 1.4571
	3	spacer collar - locating - brass or PEEK
	4	spacer collar - with spigot - brass or PEEK
	5	compression spring - 1.4310
	6	bush - threaded female - 1.4305 oder 1.4401
	7	glass disc - Sodaslime or Borosilicate
	8	gasket - non asb. fibre, BAS 400 green
	9	O-ring seal - Viton
	10	bush - threaded female - 1.4401
	11	wiper spindle - 1.4401
	12	O-ring seals - Viton
	13	bearing sleeve - PTFE
	14	wiper blade - silicon, PTFE or EPDM
	15	wiper arm - 1.4401
	16	locating pin - 1.4571

¹⁾ where wiper unit is fitted with the alternative ratchet drive mechanism.

- Drive lever - 1.4305
- Lever knob - Polycarbonate (bush brass)
- Freewheel unit - steel
- Drive boss - 1.4305
- Dust cap - synthetic resin

All product contact parts of the wiper assembly are of stainless steel.

Fitting and Assembly Instructions:

If the wiper is ordered separately, i.e. not installed into sightglass disc by the manufacturer, the assembly has to be done with regard to separate installation an operating instructions, attached to the delivery.



Sightglass Wiper type SW I built into sightglass disc

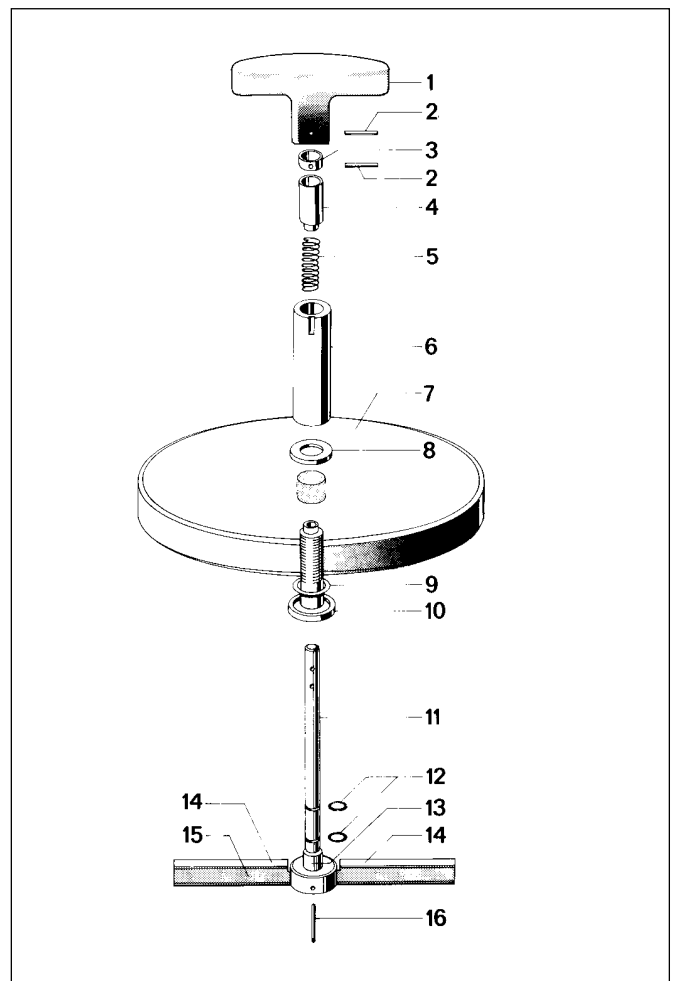

Exploded view of components

Dimensions for Sightglass Wipers type SW I

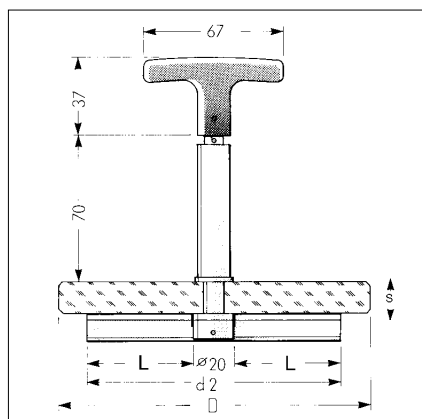

Lumiglas Wiper SW I, fitted into sightglass assembly DIN 28120



Lumiglas Wiper SW I, as shown adjoining but with Lumistar luminaire fitted.

size		special sizes										
		3	4	5*	6*	7*	8*	9	10	11	12	
nominal diameter	DN	50	80	100	125	150	200	250	300	350	400	
viewing diameter	d ₁	80	100	125	150	175	225	on request				
sightglas disc	D	100	125	150	175	200	250					
	s	15/15 ¹	15/15 ¹	15/19 ¹	15/19 ¹	15/19 ¹	15/25 ¹					
	PN max...bar	6/6 ¹	6/6 ¹	5/6 ¹	4/6 ¹	4/4 ¹	2/4 ¹					
wiper blade	d ₂	77	97	122	147	172	222	depending on glass diameter as well as inside diameter of assembly, max. 460 mm.				
part no. 7223__00 (replace with the respective figures, e.g. .065.)		.062.	.063.	.064.	.065.	.066.	.067.					

* Combination with Lumiglas luminaire Lumistar possible, NB: Combination with Lumistar 225, drive/lever version, also in combination with some luminaires model USL and ESL

¹ Data valid only for borosilicate glass

Spare parts

wiper blades	for sizes	L	silicone rubber, part number	PTFE, part number
	3	28,5	9468.062.00	9468.072.00
	4	38,5	9468.063.00	9468.073.00
	5	51	9468.064.00	9468.074.00
	6	63,5	9468.065.00	9468.075.00
	7	76	9468.066.00	9468.076.00
	8	101	9468.067.00	9468.077.00
	9 to 12	depending on glass diameter and inside diameter of the fitting		
seals	for sizes	diam. x s	part number	
Viton-O-ring seal (no. 12 overleaf)	1 to 6	4 x 1	0862.019.00	
Viton-O-ring seal (no. 9 overleaf)	1 to 6	12,37 x 2,62	0862.024.00	

Ordering Information:

e. g. LUMIGLAS-Sightglass Wiper type SW I, size 3, wiperblade PTFE. If a sightglass disc is needed as well, please specify the following data:

- Borosilicate or soda lime glass (see data sheet 00.03/...)
- Sightglass disc size (diameter x s)
- nominal fittings diameter DN
- effective operating pressure for this vessel
- for wiper blades sizes 9 and larger, please specify the inside diameter of the fitting

Note:

A sightglass disc is not automatically included in the supply. Please order sightglass disc separately.

RD 2x1000/10.01 3755.171

All dimensions in mm unless stated otherwise. Subjects to change without prior notice.